

DAVOS45 120

PL> INSTRUKCJA MONTAŻU
D >MONTAGEANLEITUNG
GB>ASSEMBLY INSTRUCTIONS
NL>HANDLEIDING VOOR DE MONTAGE
F >MODEL D'EMPLOI
CZ> POKYNY PRO INSTALACI
SK> INSTRUKCJA MONTAŽUNÁVOD

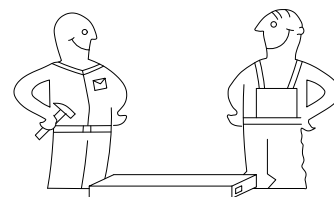

NA INŠTALÁCIU
HR> UPUTE ZA MONTAŽU
SRB> УПУТСТВО ЗА УГРАДЊУ

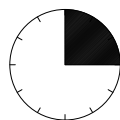

180 minut
180 minuten
180 minutes
180 minuten
180 minutes

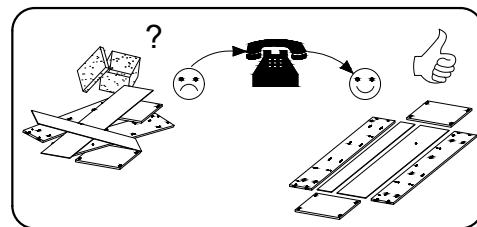
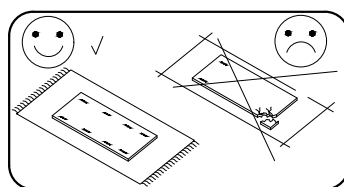
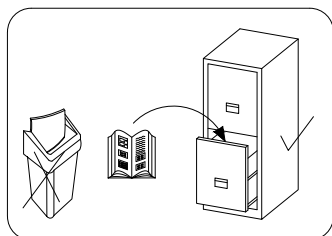
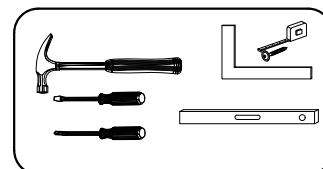

**Uwaga / Achtung / Caution / Opgelet / Attention /
Pozornost / Pozornost' / Pažnja / Пажња**



PL>Czyszczenie należy wykonać wyłącznie za pomocą ściereczki lub lekko nawilżonego ręcznika.
Nie stosować środków czyszczących do szorowania.

Szanowny kliencie, jeśli podczas montażu stwierdzisz uszkodzenie lub brak części, proszę podaj jej kod alfanumeryczny lub zaznacz ją na instrukcji montażu i prześlij wraz z protokołem reklamacyjnym

D >Bitte nur mit einem Staubtuch oder leicht feuchtem Lappen reinigen. Keine scheuerenden Putzmittel verwenden.

Sehr geehrter Kunde, sollte ein Teil fehlen oder beschädigt sein, kreuzen Sie dies bitte deutlich auf der Montageanleitung an und schicken Sie die Montageanleitung mit ein.

GB>Please only clean with a duster or a damp cloth. Do not use any abrasive cleaners.

Dear customer, should there be any piece missing or damaged, kindly mark this piece clearly on the attached assembly instructions and return them to us.

NL>Reinig alleen met een stofdoek of een lichtjes vochtige doek. Gebruik geen schurende poetsmiddelen.

Geachte klant, in het geval van beschadiging of ontbrekende onderdelen tijdens de montage, gelieve de alfanumerieke code in de montagehandleiding te vermelden of te markeren en samen met het klachtenprotocol mee te sturen

F >Le nettoyage se fait uniquement à l'aide d'un torchon ou d'une serviette légèrement mouillée.

Cher client, en cas de dommages ou de pièces manquantes lors du montage, veuillez fournir ou marquer le code alphanumérique dans le manuel de montage et l'envoyer avec le protocole de réclamation

CZ>Čištění by mělo být prováděno pouze hadříkem nebo mírně navlhčeným hadříkem.
Nepoužívejte abrazivní čisticí prostředky.

Vážený zákazníku, pokud při montáži zjistíte poškozený nebo chybějící díl, uveďte jeho alfanumerický kód nebo jej označte v montážním návodu a zašlete spolu s reklamačním protokolem

SK>Čistenie by sa malo vykonávať iba handričkou alebo mierne navlhčenou utierkou. Nepoužívajte čistiace prostriedky na drhnutie..

Vážený zákazník, ak pri montáži nájdete poškodený alebo chýbajúci diel, uveďte jeho alfanumerický kód alebo ho označte na montážnom návode a zašlite spolu s reklamačným protokolom

HR>Čišćenje se smije vršiti samo krpom ili blago navlaženim ručnikom. Nemojte koristiti sredstva za čišćenje.











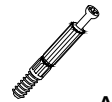

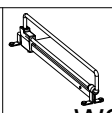

Poštovani kupče, ako tijekom sastavljanja nađete oštećeni dio ili dio koji nedostaje, molimo da dostavite njegov alfanumerički kod ili ga označite u priručniku za sastavljanje i pošaljite ga zajedno s protokolom reklamacije

SRB>Чишћење треба вршити само крпом или благо влажним пешкиром. Немојте користити средства за чишћење.

Поштовани купче, ако током монтаже нађете оштећен или недостаје део, наведите његов алфанумерички код или га означите у приручнику за монтажу и пошаљите га заједно са рекламационим протоколом

Karta servisowa /Service Karte /Service card /Service kaart /Carte de service/ služební karta/služobný preukaz/servisna kartica/сервисна картица

AKCESORIA / ZUBEHÖR / ACCESSORIES / ACCESSOIRES / ACCESSOIRES / PŘÍSLUŠENSTVÍ / DOPLNKY / PRIBOR / ПРИБОР

8.0x35  D	 A	 B	 X	 WS	 WD	 WG	L-1166  SG	L-1166  SD
12	36	36	36	2	4	4	1	1
 S1	 DP	 Y	 SP	 P1	 M	 H	 HC	
110	4	5	4	16	8	3.5x16 40		3.5x16 42

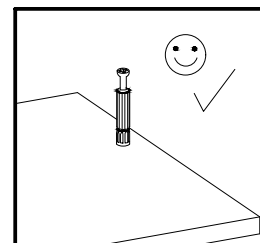
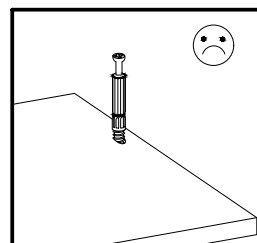
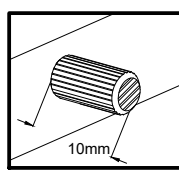
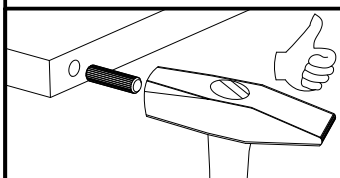
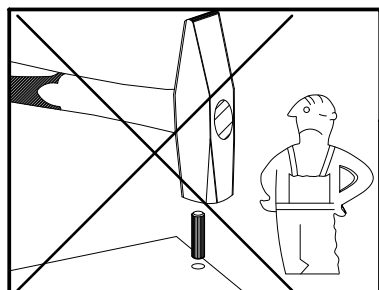
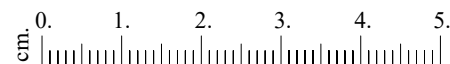

opcja 1

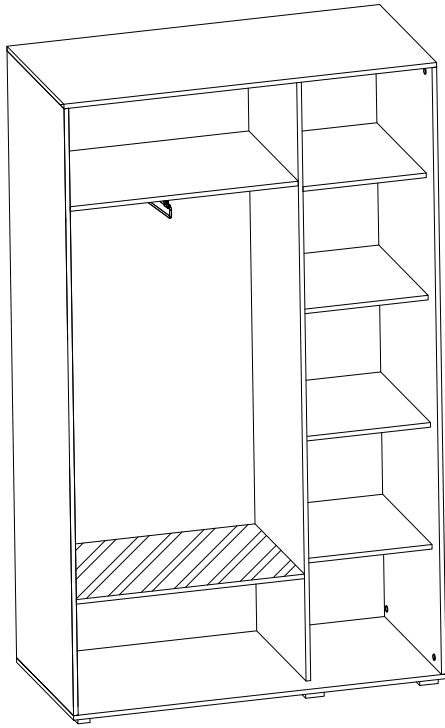

opcja 2

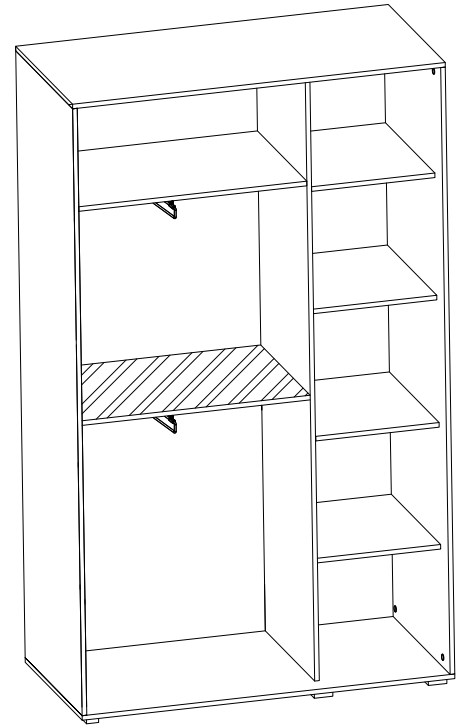

1.	1	1202	452	16
2.	1	1202	452	16
3.	1	2300	450	16
4.	1	2300	450	16
6.	1	2300	340	16
7.	4	476	330	16
8.	2	675	330	16
9.	6	1195	386	3
10.	12	2258	600	16

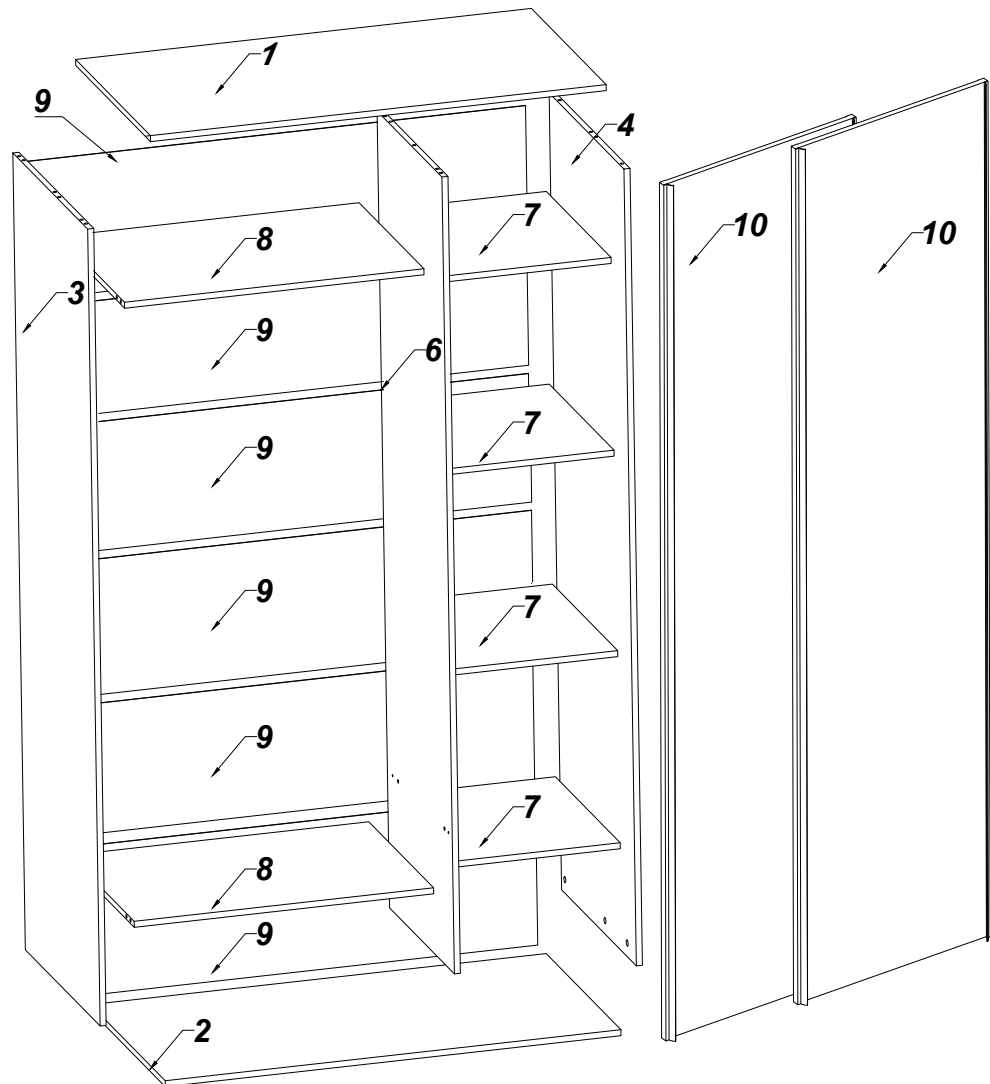

1

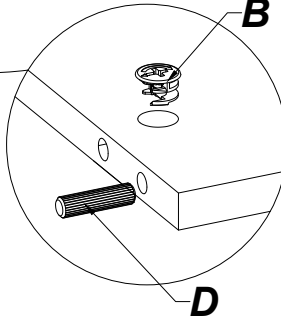
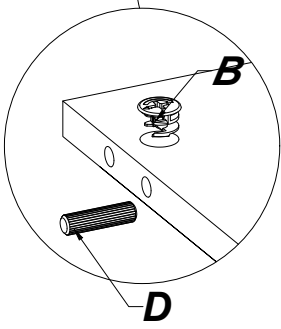
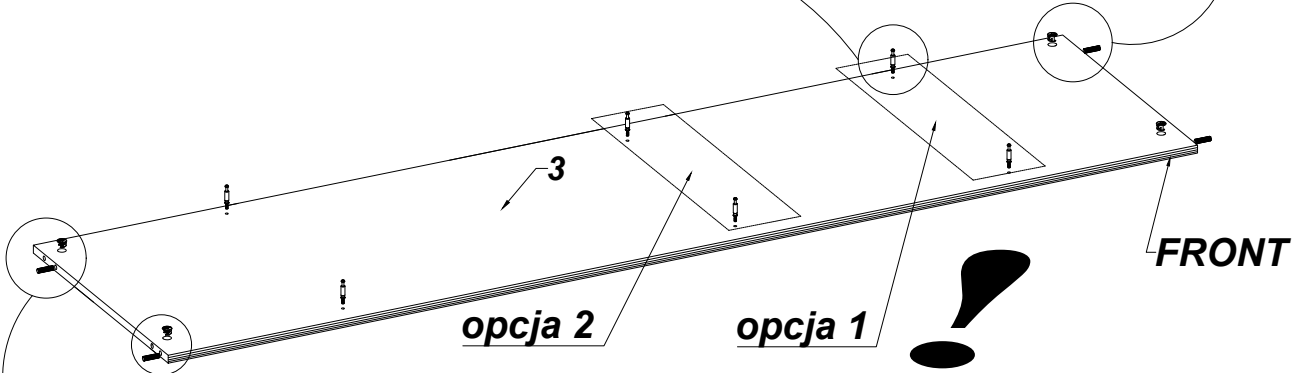
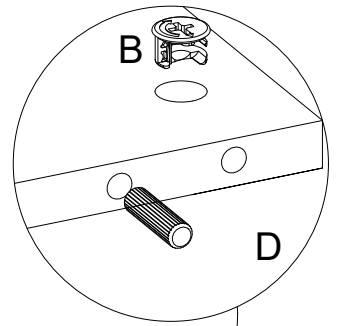
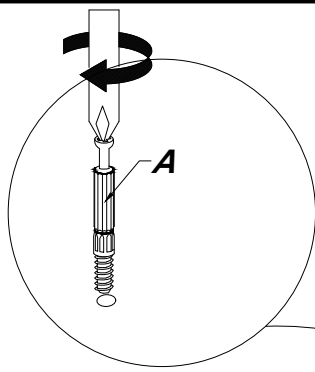

2

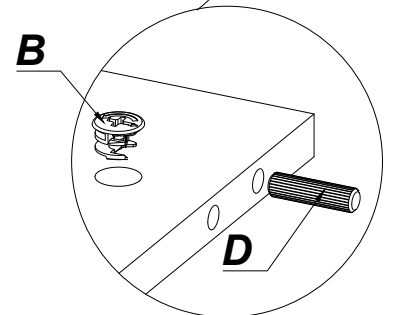
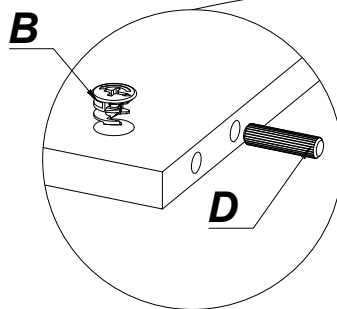
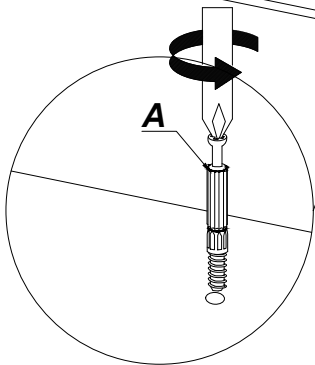
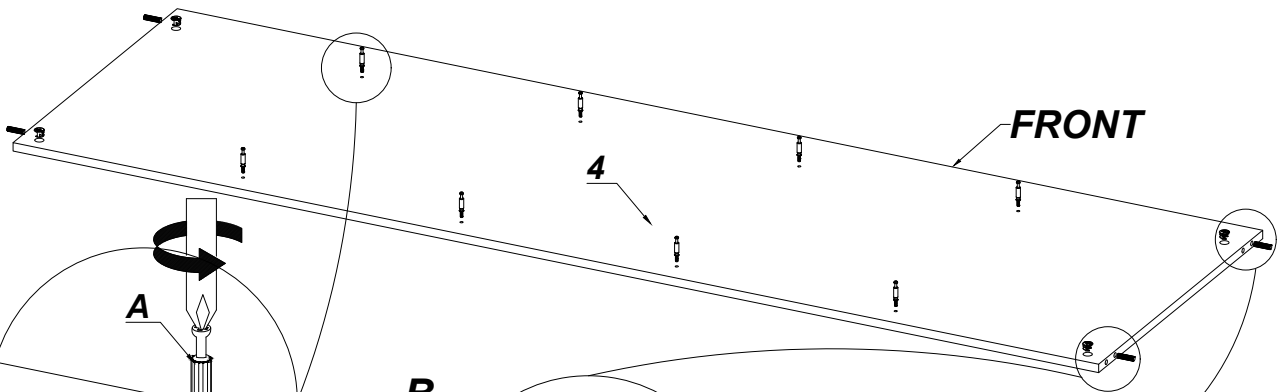
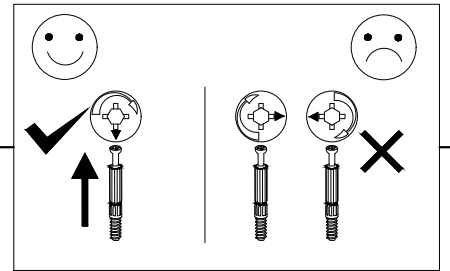
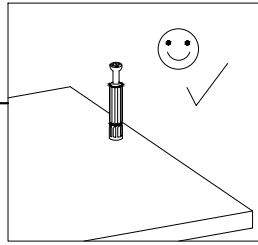
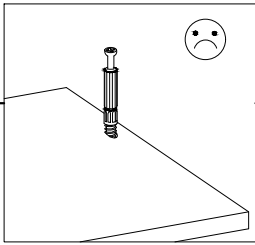

3

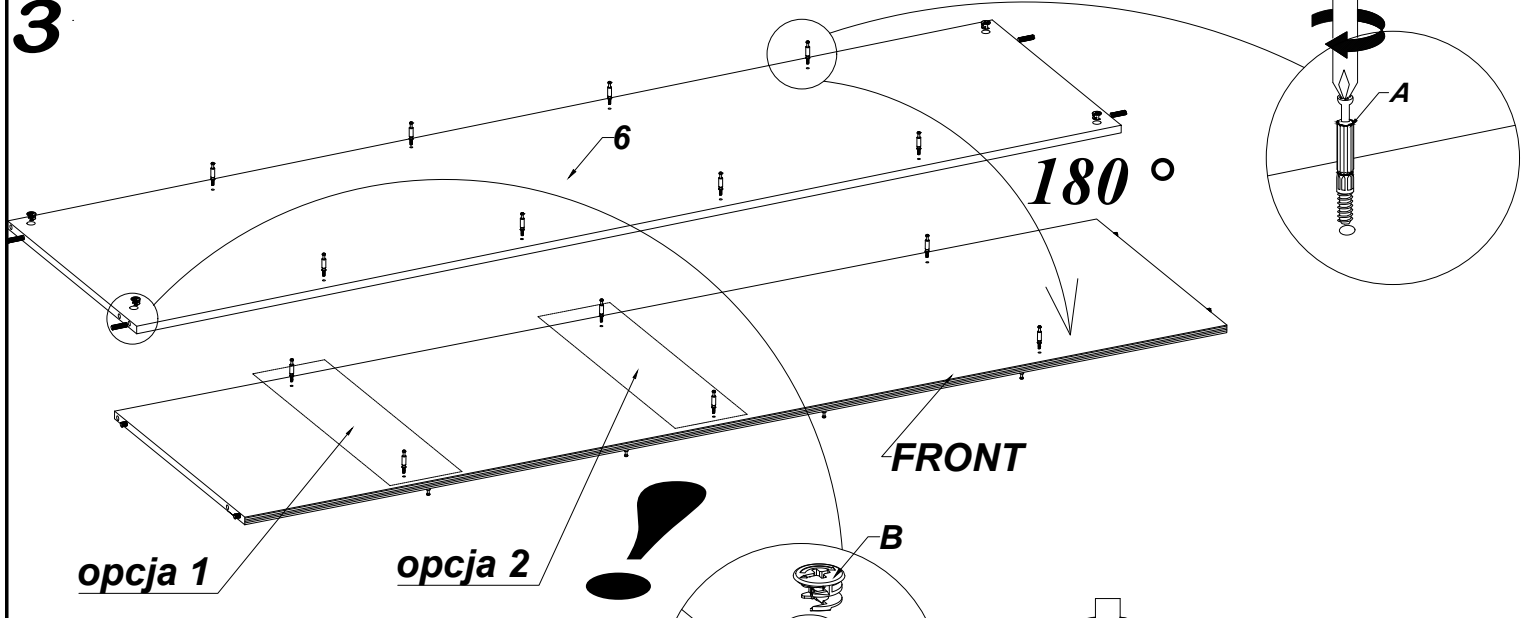

4

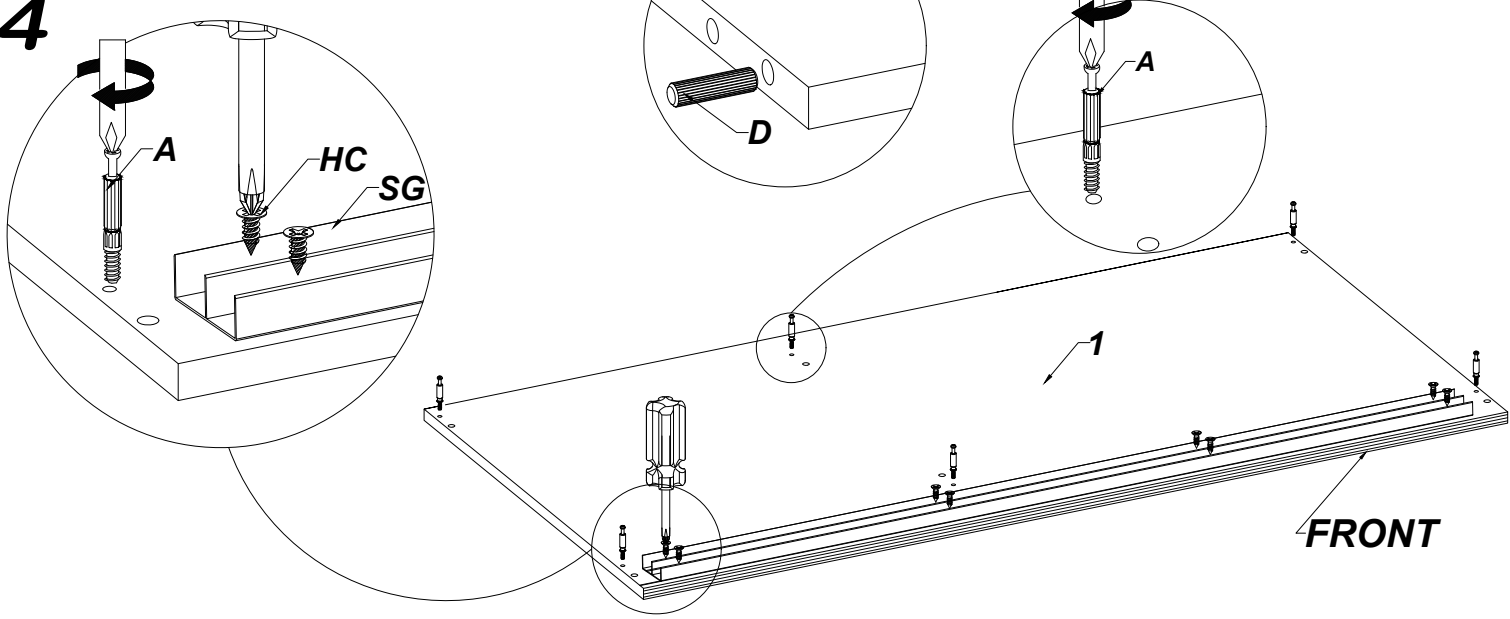

5

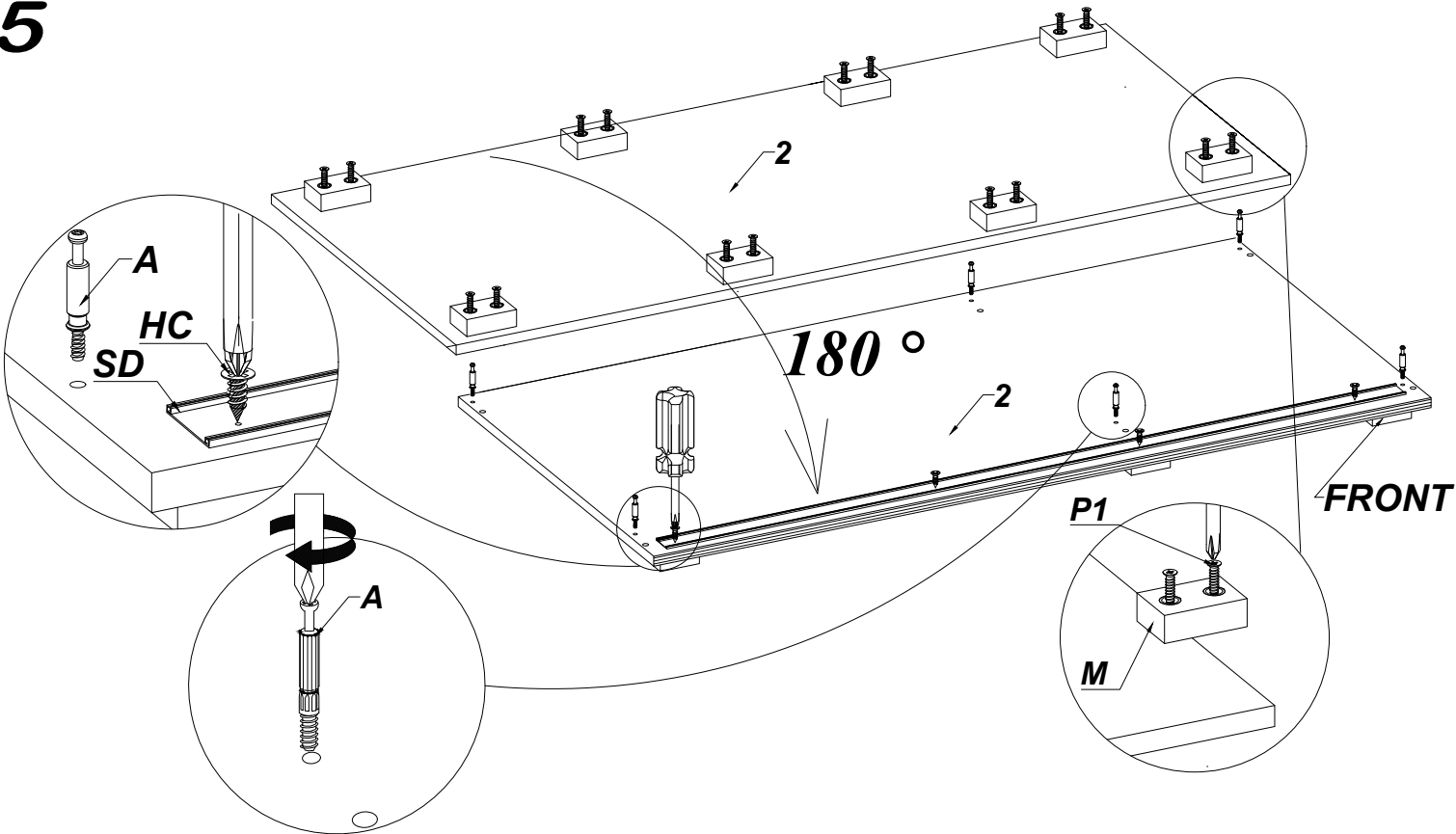

6 opcja 1
1x

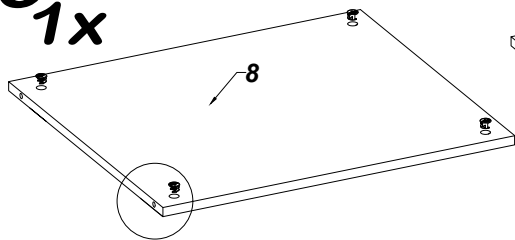

2x opcja 2

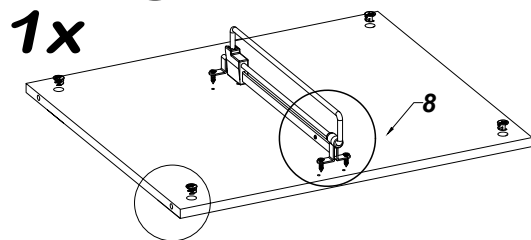
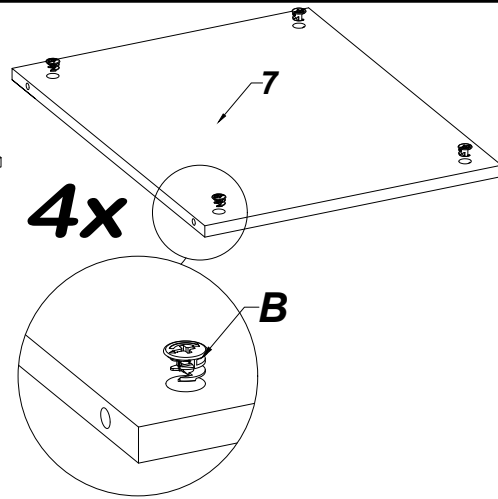
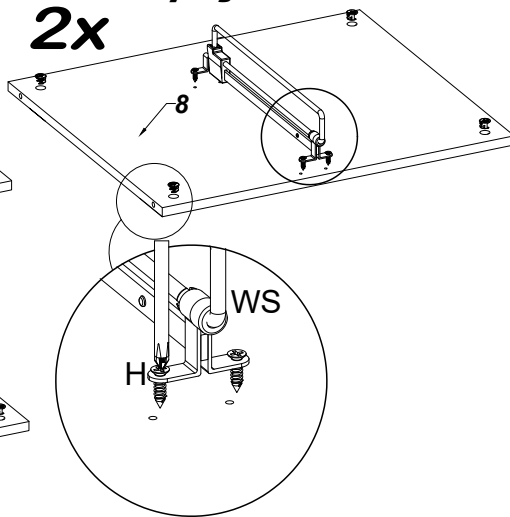

7 opcja 1

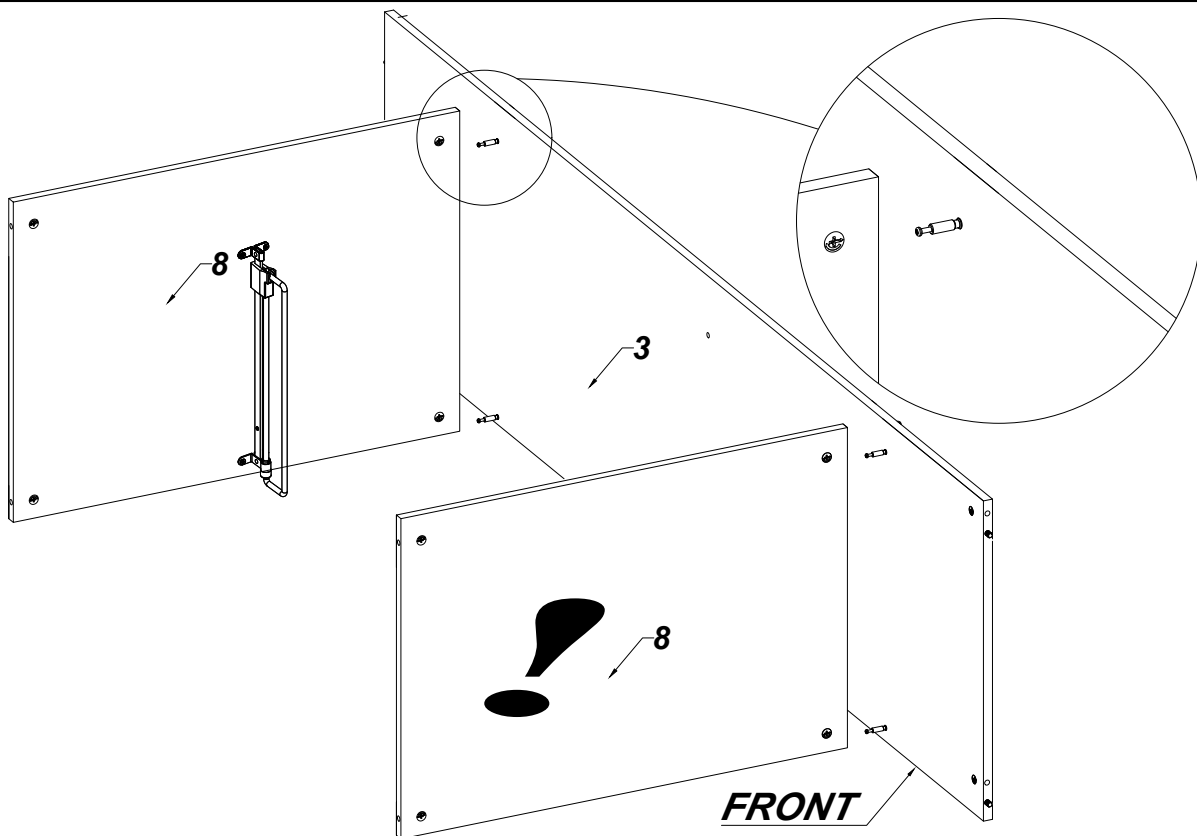

8 opcja 2

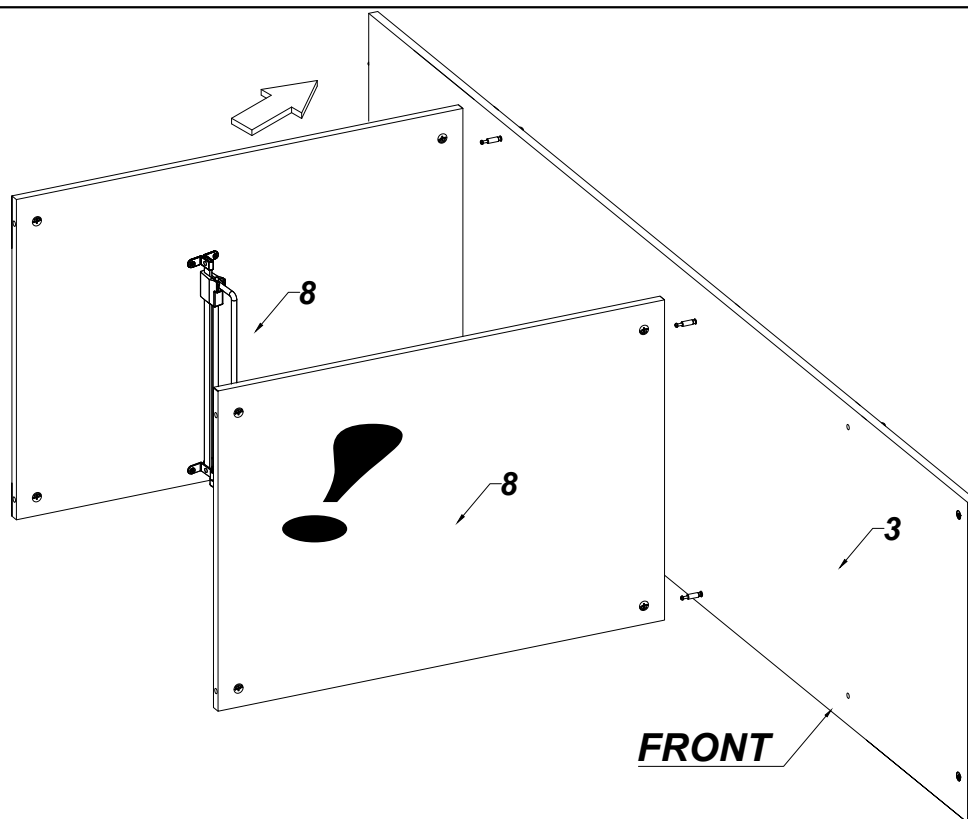

9

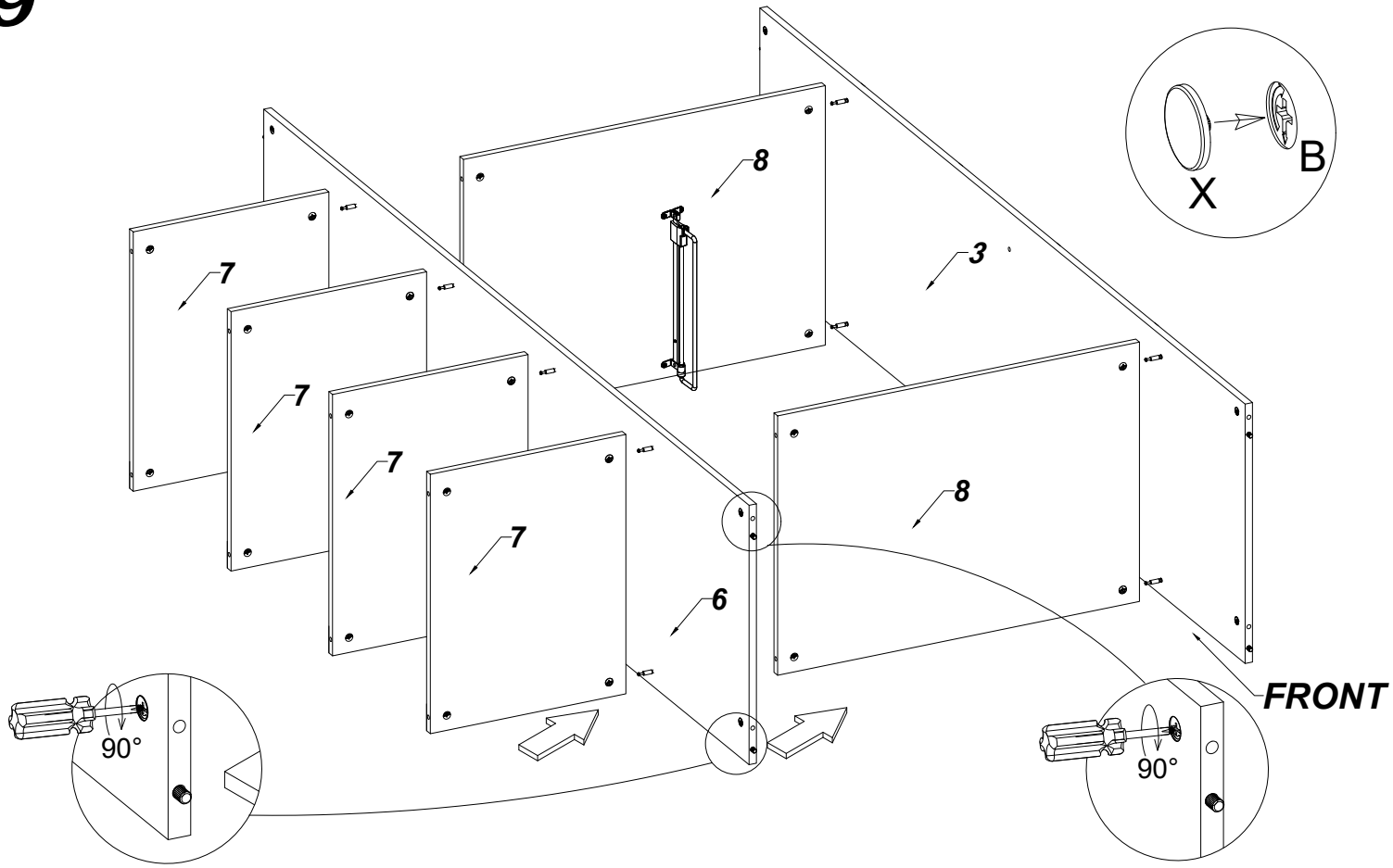

10

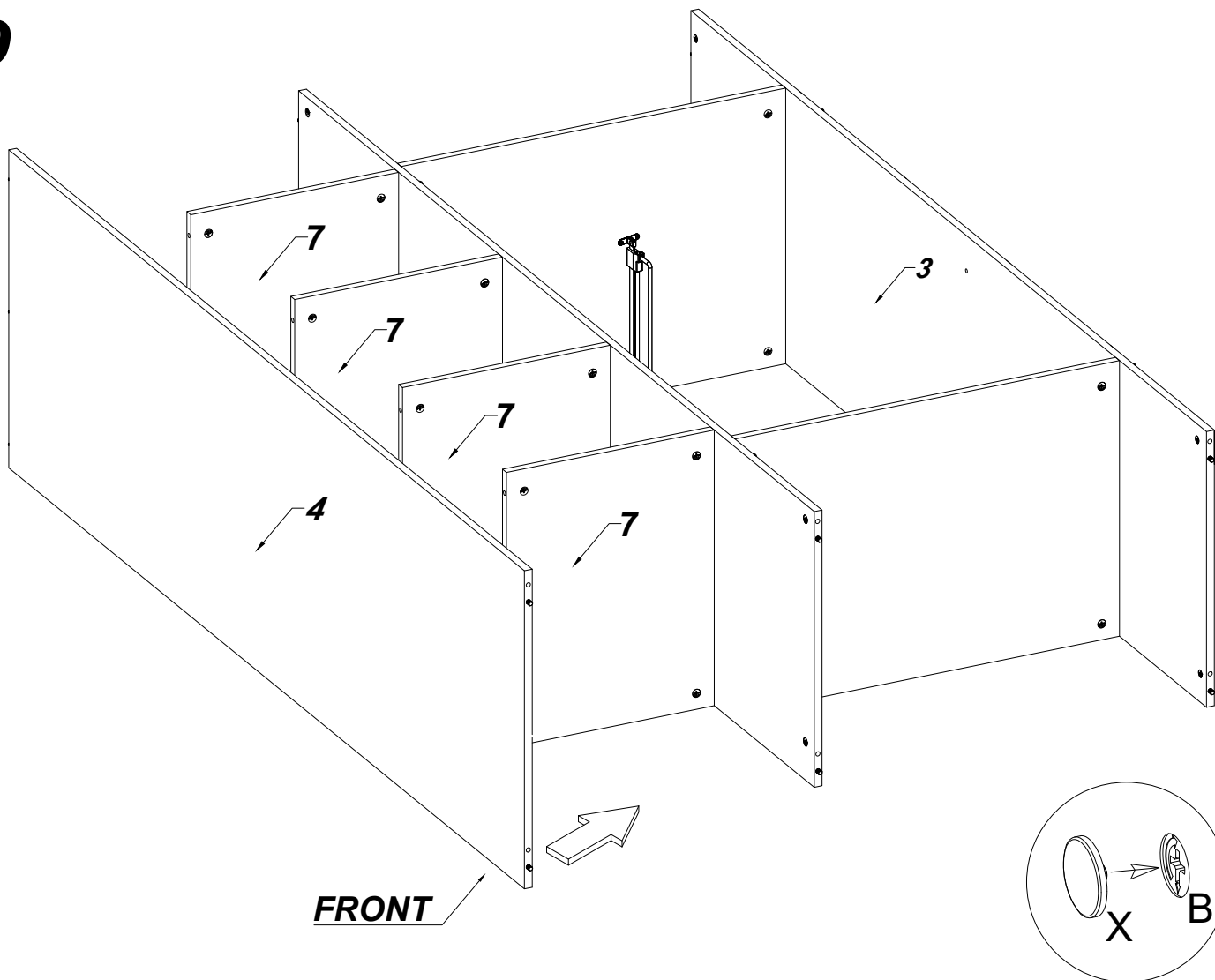

11

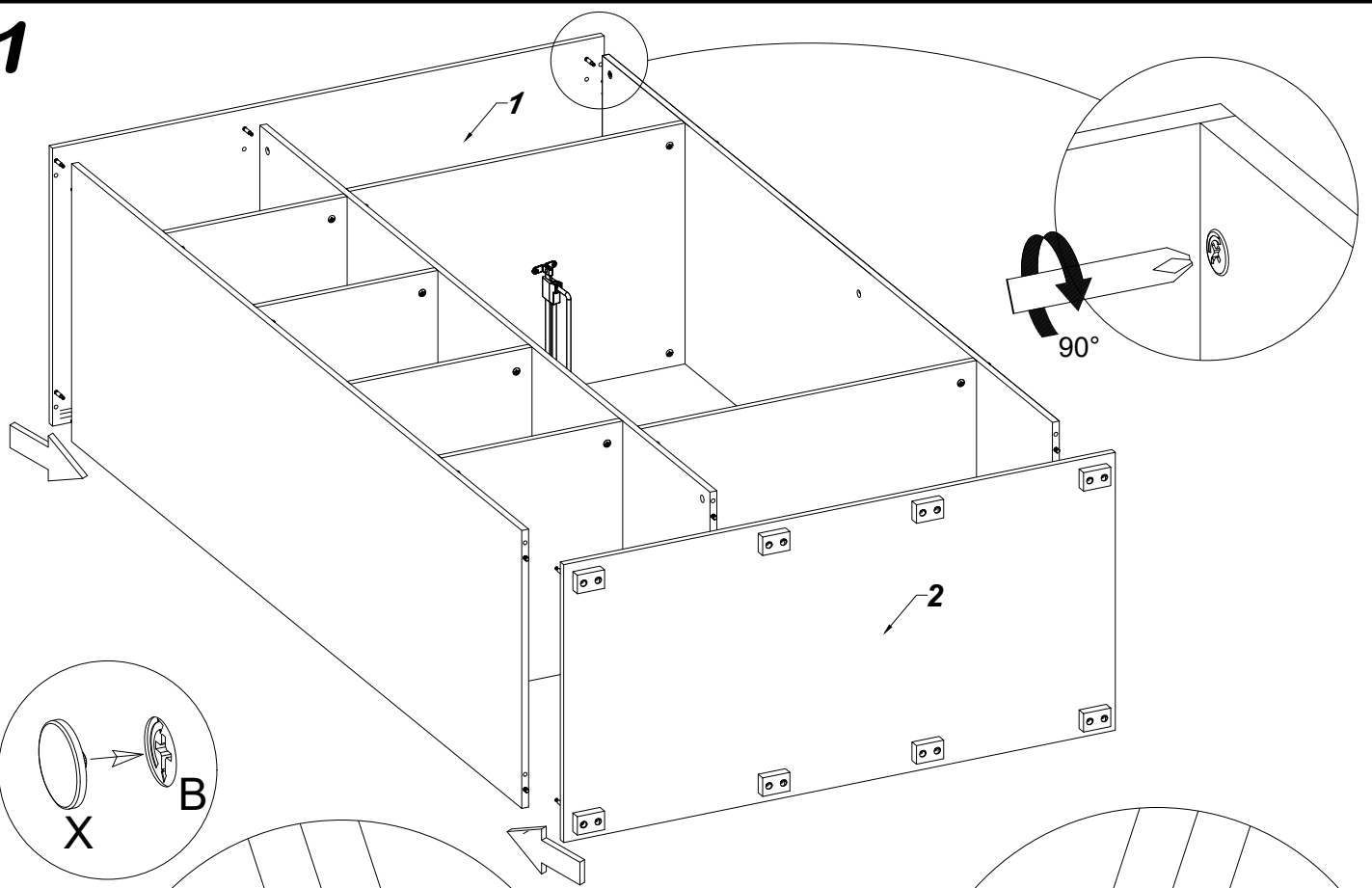

12

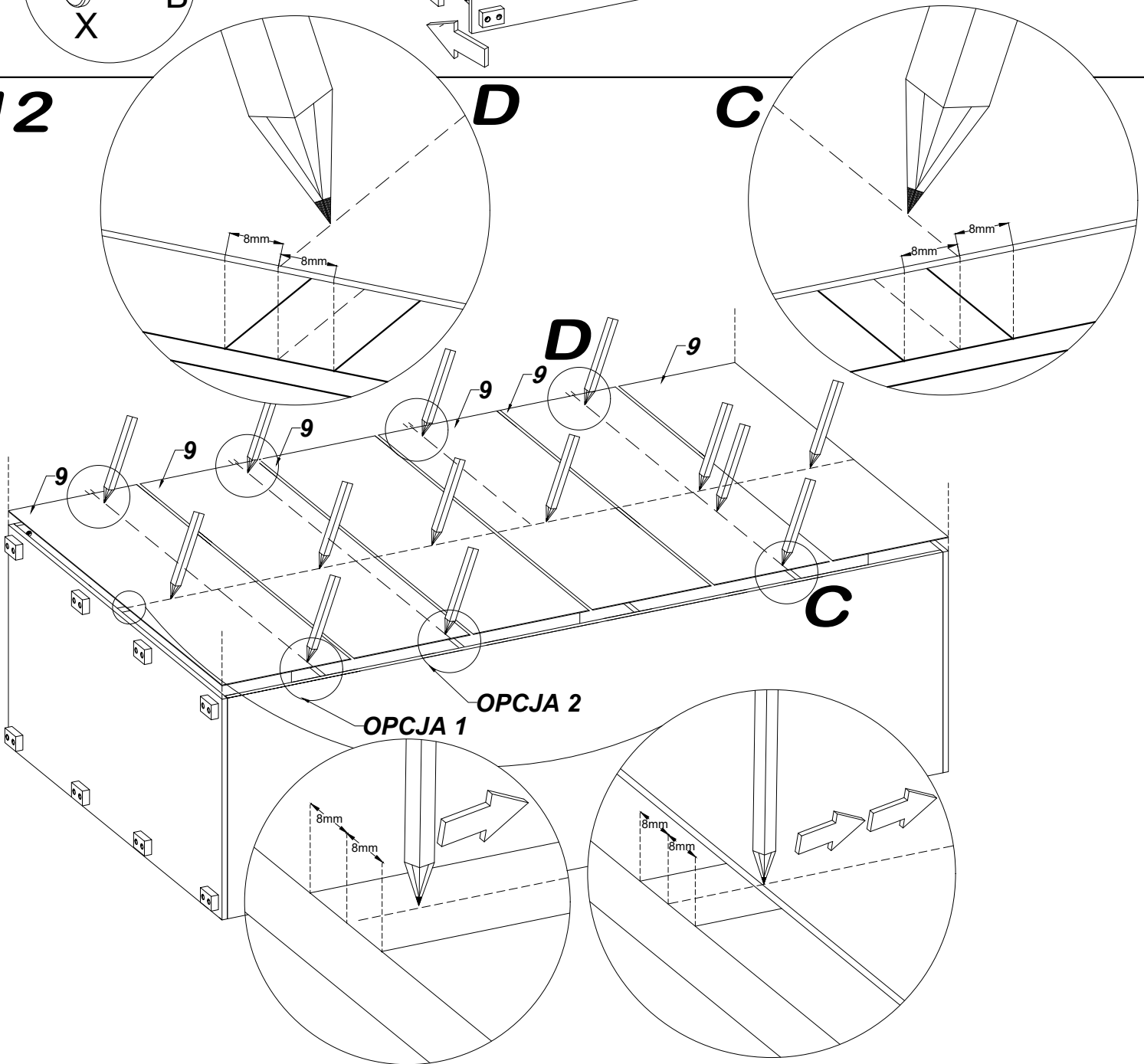

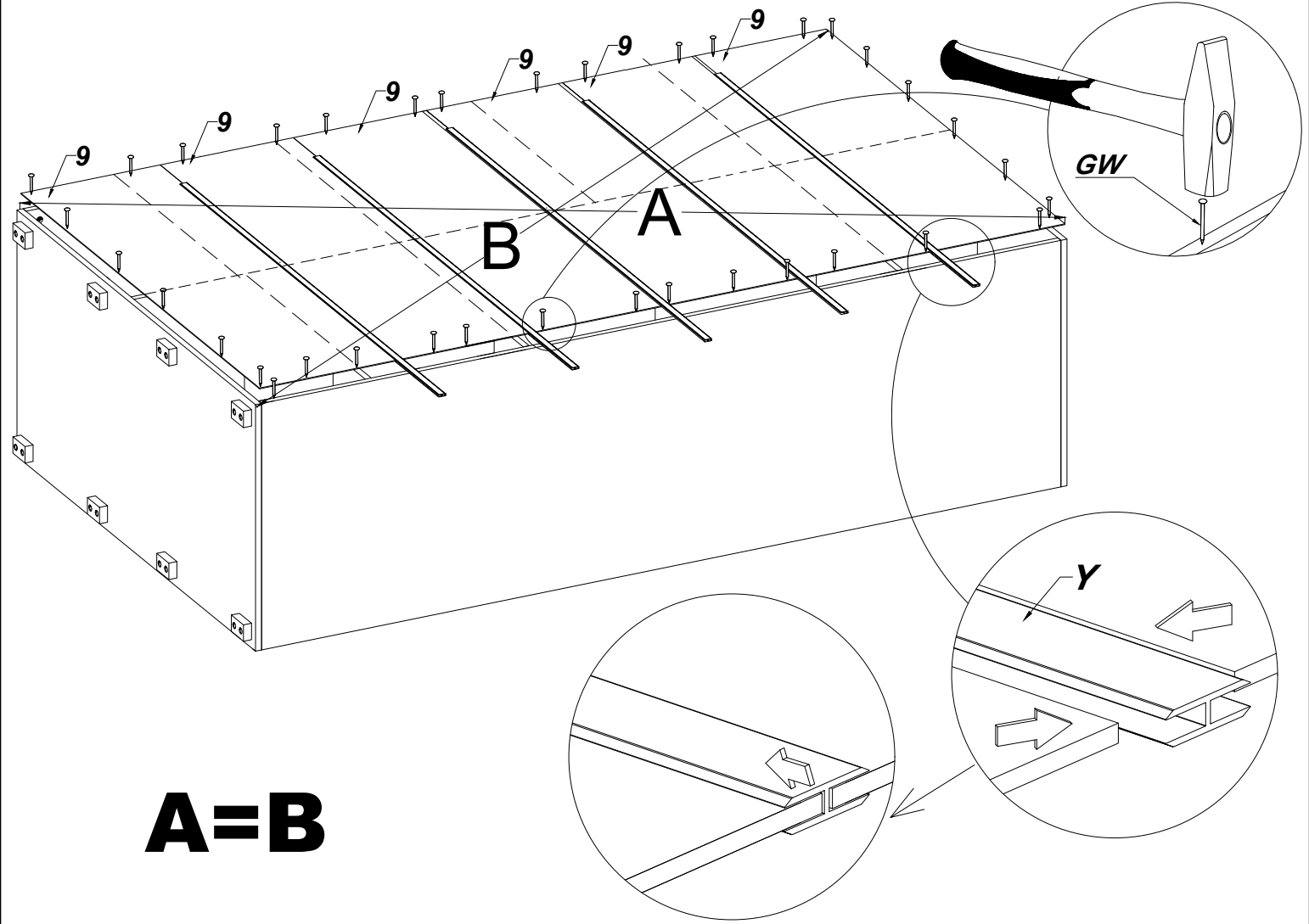

A=B

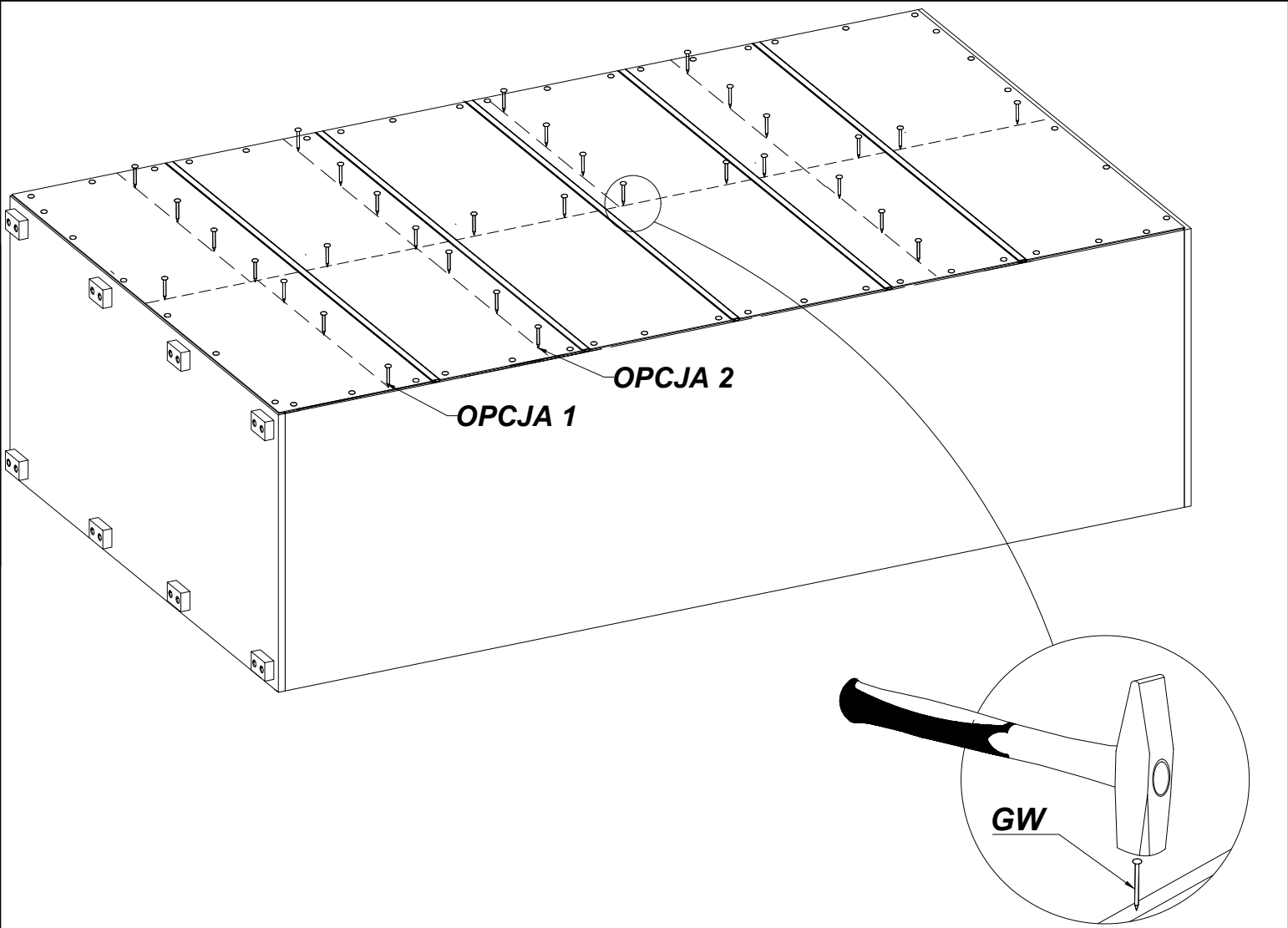

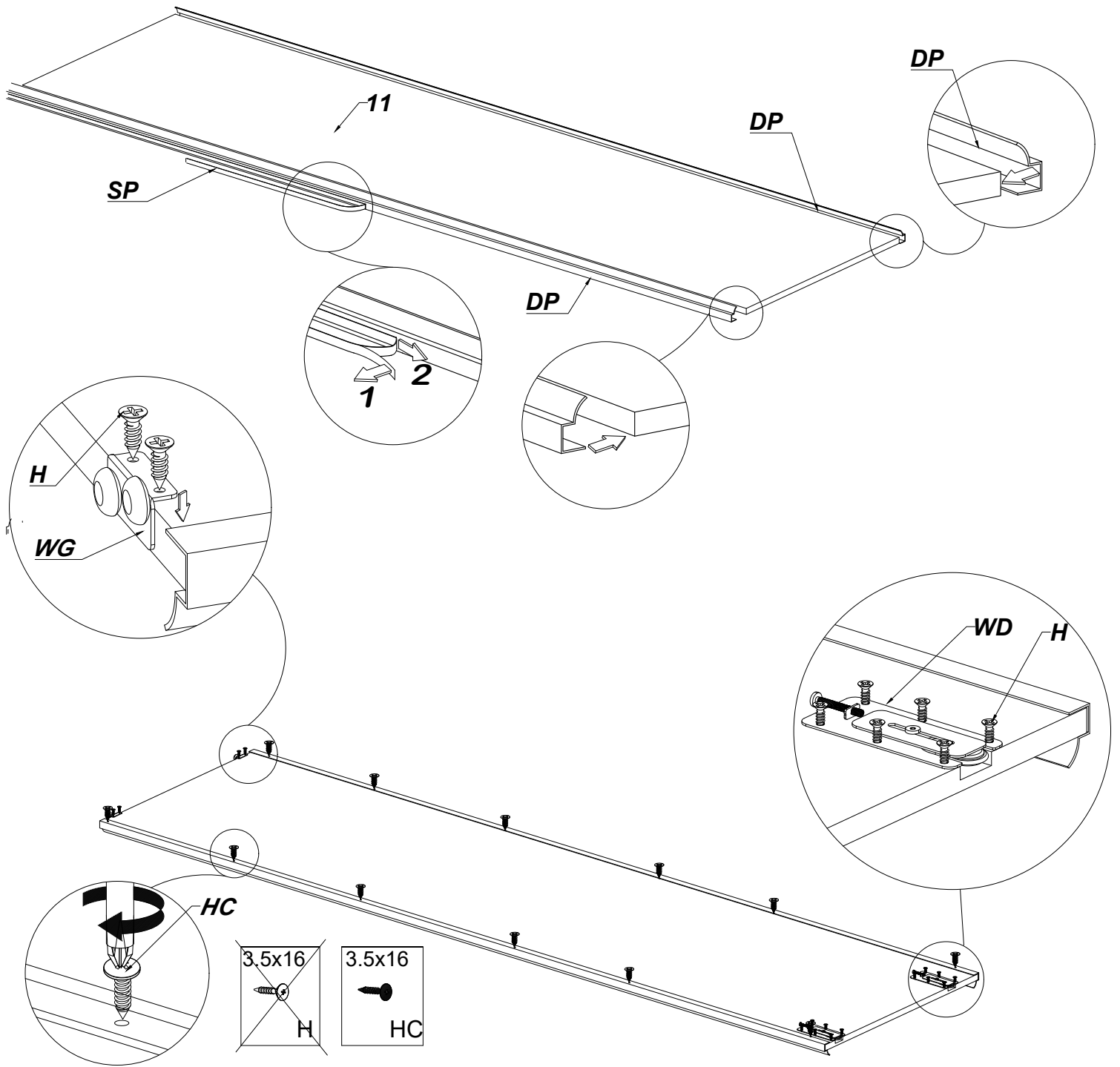

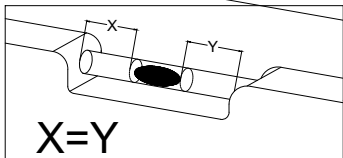
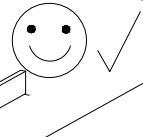
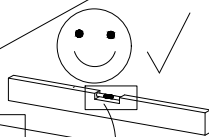
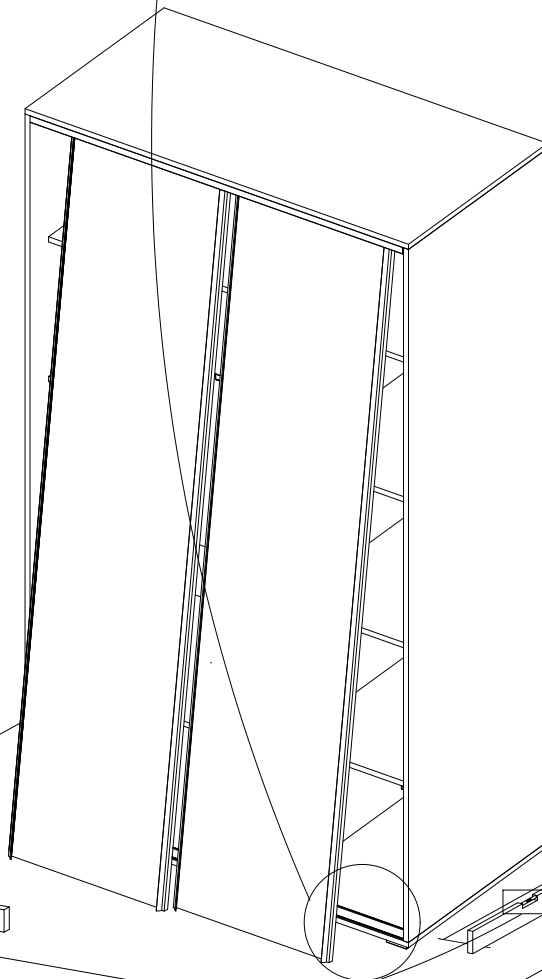
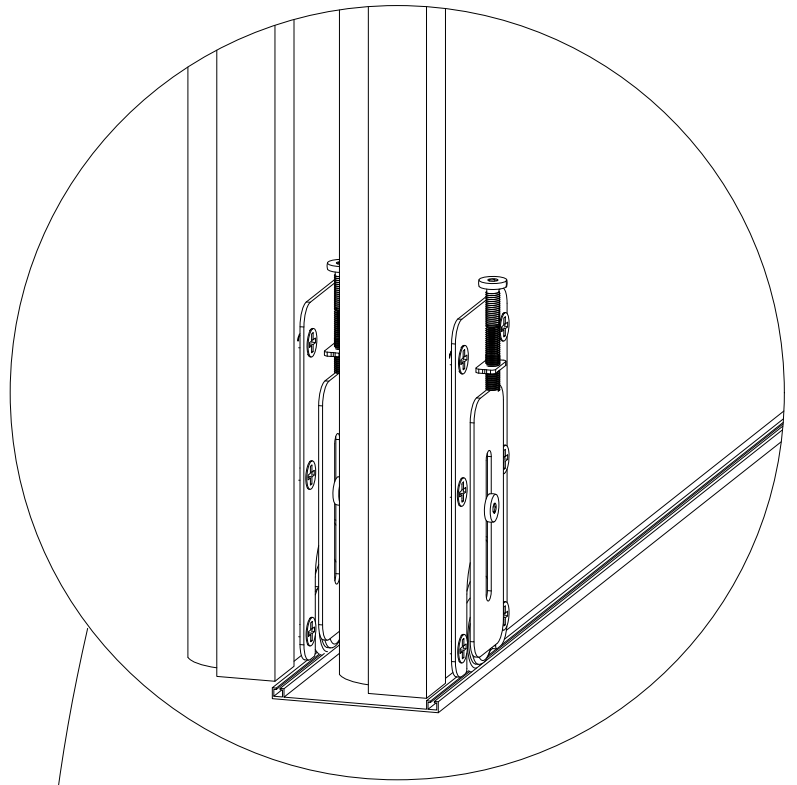

X=Y

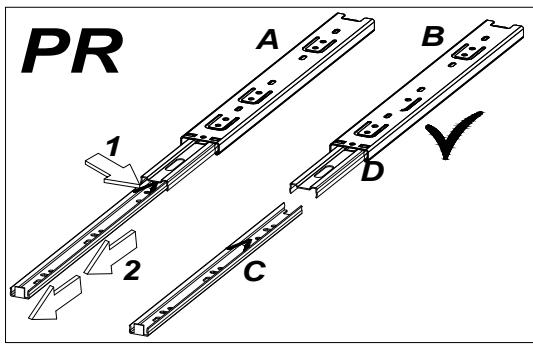

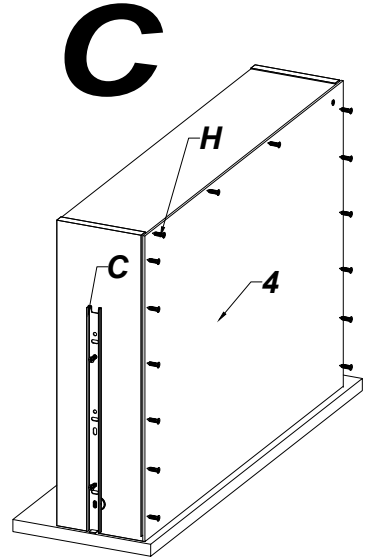
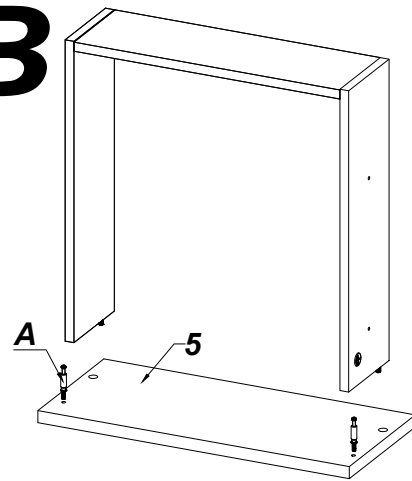
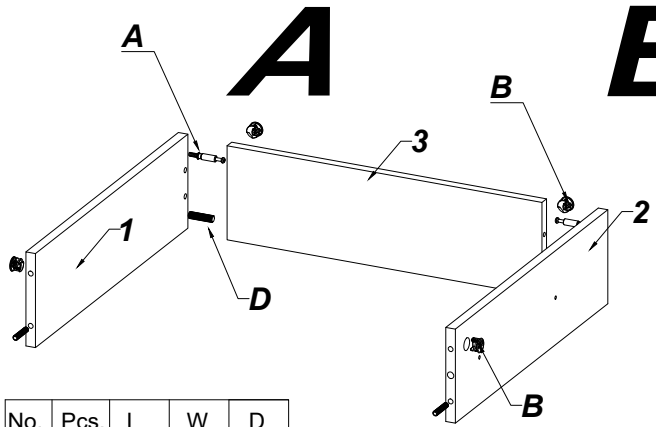

		3.5x16
PR		H
2		24
X	A	M
8	8	8
		D
		8

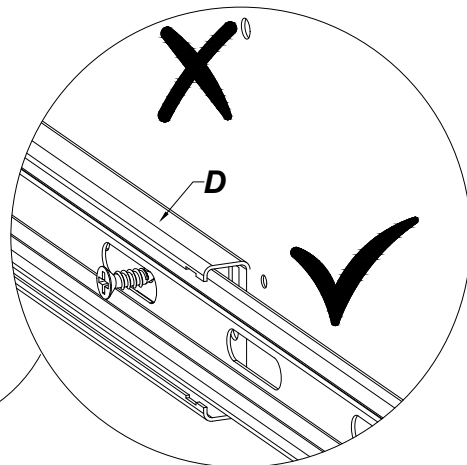
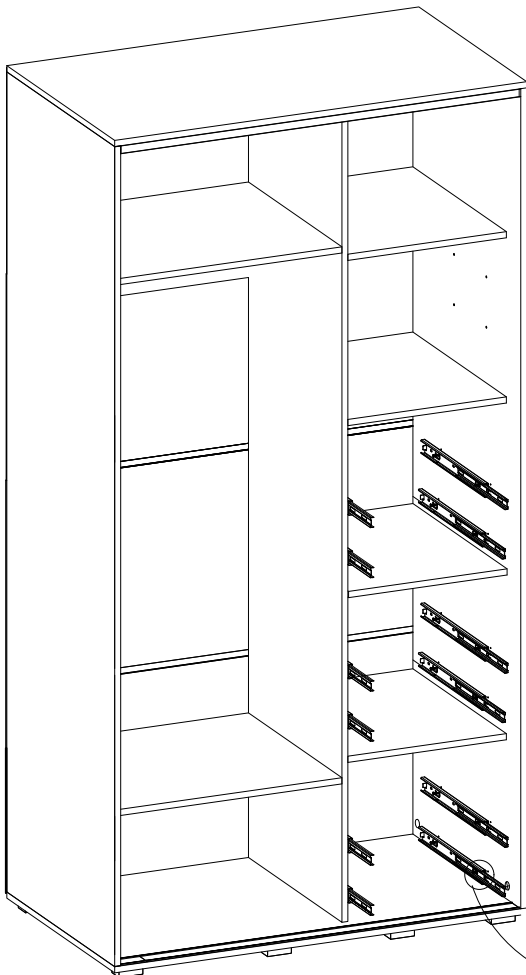

No.	Pcs.	L	W	D
1.	2	300	110	16
2.	2	300	110	16
3.	2	418	110	16
4.	2	305	446	3
5.	2	160	468	16

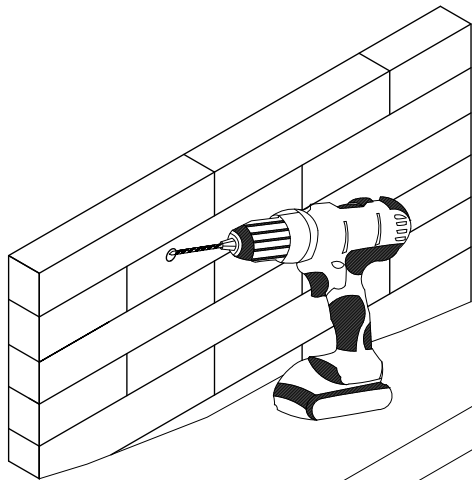

1

3.5x16	
	
H	MS1
1	1

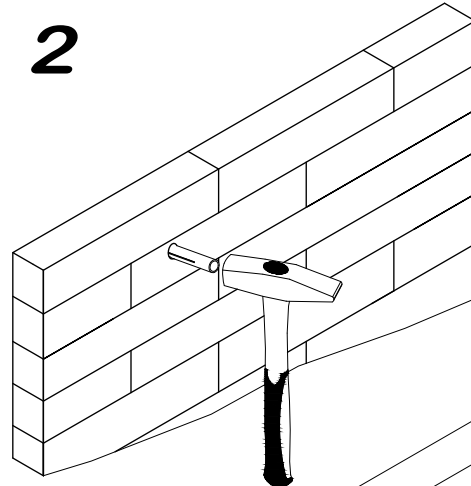
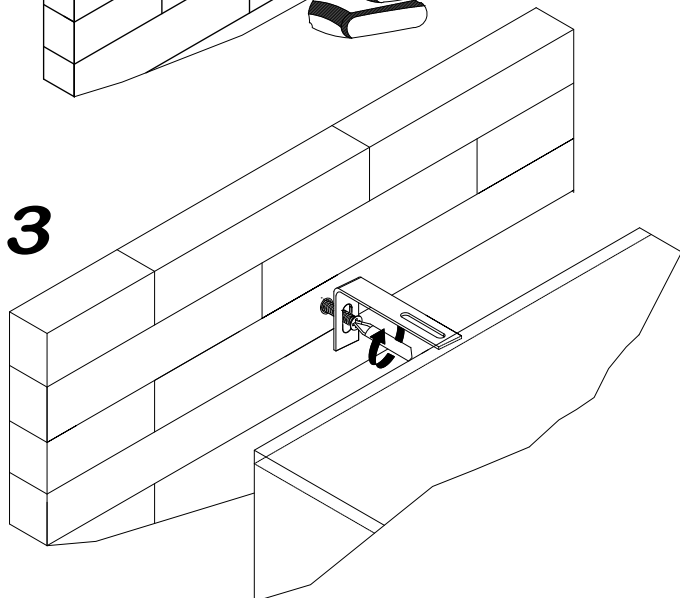
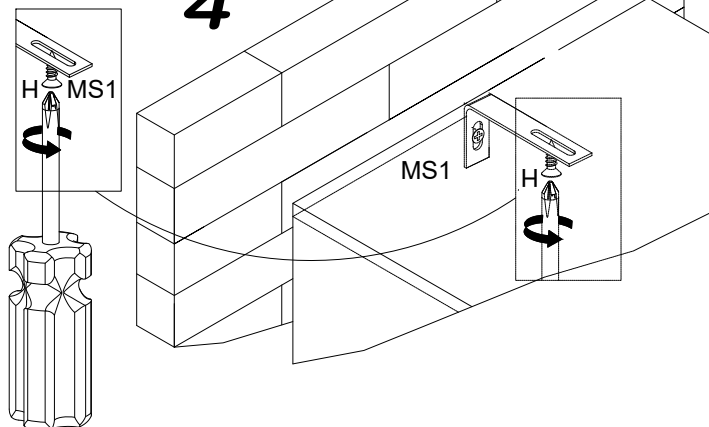
2**3****4**

!!! Kołek montażowy należy dobrać do odpowiedniego rodzaju ściany - do zakupienia we własnym zakresie !!!

Przy montażu artykułu na ścianie należy zastosować odpowiednie do niej zamocowania. W razie wątpliwości prosimy zasięgnąć porady fachowca.

PL

Uwaga: Mocowanie mebla do ściany mogą przeprowadzić wyłącznie wykwalifikowane osoby, z uwagi na zastosowanie odpowiednio dopasowanych kołków do rodzaju ściany.

!!! Der Befestigungsstift sollte für den entsprechenden Wandtyp ausgewählt werden – er muss selbst erworben werden !!!

Für andere Wandaufbauten sind eventuell Spezialdübel und andere Schrauben notwendig. Ziehen Sie gegebenenfalls eine Fachkraft zurate.

D

Achtung: Die Befestigung des Möbelstückes an der Wand muss von einer fachkundigen Person vorgenommen werden, da für die Montage an die Wand angepasste Dübel erforderlich sind.

!!! The mounting pin should be selected for the appropriate type of wall - to be purchased on your own !!!

Special dowels and other screws may be necessary for other wall constructions. If necessary, please consult a qualified professional.

GB

Attention: A qualified professional is required when mounting furniture to the wall since dowels corresponding to the wall are required for this.

!!! La goupille de fixation doit être sélectionnée pour le type de mur approprié - elle doit être achetée séparément !!!

Pour les autres constructions de murs, il faut éventuellement des chevilles spéciales et d'autres vis. Faites-vous conseiller par un spécialiste.

F

Attention : La fixation du meuble contre le mur doit être effectuée par une personne compétente car, pour le montage mural, il faut utiliser des chevilles adaptées.

!!!De bevestigingspin moet worden geselecteerd voor het juiste type muur - deze moet afzonderlijk worden aangeschaft !!!

Voor andere muurconstructies zijn eventueel speciale pluggen en andere schroeven noodzakelijk. Consulteer eventueel een vakman

NL

Opgelet: een vakkundige persoon dient het meubelstuk aan de muur te bevestigen; voor de montage aan de muur zijn immers aangepaste pluggen vereist.

!!! Upevňovací trn by měl být vybrán pro příslušný typ stěny - je třeba jej zakoupit samostatně !!!

Pro jiné skladby stěn budou případně nutné speciální hmoždinky a jiné šrouby. Poradte se případně s odborníkem.

CZ

Pozor: Montáž nábytku na stěnu musí provést odborník, protože k montáži na stěnu jsou zapotřebí upravené hmoždinky.

!!! Upevňovací kolík by mal byť vybraný pre príslušný typ steny - je potrebné ho zakúpiť samostatne !!!

Preiné steny sú potrebné príp. špeciálne hmoždinky a iné skrutky. V prípade potreby sa poraďte s odborníkom.

SK

Pozor: Upevnenie nábytku na stenu musí vykonať odborník, nakoľko sú pre montáž na stenu potrebné vhodné hmoždinky.

!!! Zatit za pričvrščivanje treba odabrati za odgovarajuću vrstu zida - treba ga kupiti zasebno !!!

Kada montirate proizvod na zid, koristite odgovarajuće pričvršne elemente. Ako ste u nedoumici, obratite se stručnjaku.

HR

Napomena: Pričvrščivanje namještaja na zid smiju izvoditi samo kvalificirane osobe, zbog upotrebe pravilno usklađenih tipli s vrstom zida.

!!! Пин за причвршћивање треба одабрати за одговарајући тип зида - треба га купити засебно!!!

Када монтирате артикал на зид, користите одговарајуће причвршћиваче. Ако сте у недоумици, обратите се професионалцу.

SRB

Напомена: Причвршћивање намештаја на зид смеју да обављају само квалификоване особе, због употребе типлова који су правилно прилагођени типу зида